

1/48^{scale} ASSUALT MOD

Model Kit by SMT: <http://smt.theshoppe.com>

Pattern Maker: Alfred Wong, website: <http://members.rogers.com/alterego>

Type: Single Seat Starfighter
Manufacturer: Kuat Systems Engineering
Operators: Various

The Cloakshape is one of the older starfighters commonly found across the galaxy, serving with mercenaries, pirate gangs and private militias. It is rugged and reliable, and has a performance similiar to the Z-95 Headhunter MK. II. Like the Headhunter the Cloakshape is easily customized and can be found in an endless variety. Few even meet the original manufacturer's specifications. This kit upgrades the basic Cloakshape into a heavy assault ship.

1:48 ASSUALT MOD

Before you begin to assemble your model kit, study the instructions carefully. This will help familiarize you with the location and parts required for assembly. If you wish to paint your model, various components should be painted before the parts are attached. The appropriate color is stated in the paint guide at the end of the instructions. This kit is molded from a plastic resin. Use of a superglue is required for assembly.

For the best finish your model should be painted even if molded in color. Paint should be applied in several light coats rather than one heavy one (the first coat should not completely cover the surface). Each layer should dry thoroughly before sanding with #1200 wet or dry sandpaper that is slightly damp, except for the final coat.

**** Be careful not to remove any detail while sanding ****

Keep your hands clean when working with the model prior to painting. Always thoroughly wash parts to remove any trace of mold release agents, body oils from your hands and sanding residue. A solution of dish washer detergent and water is recommended. Use a tack cloth to dry.

Parting lines and glue joints should be filled and sanded before painting. A filler putty designed for use on plastics should be used to blend and fill contours. This should be applied only after the first primer coat.

When painting a body of two or more colors, the lighter color should be painted first. Use frosted or liquid masking agent to protect any areas you do not want painted. After the paint is dry to the touch you may remove the masking agent. Use a very fine brush to touch up any edges that may require it. If decals are added do so before applying the gloss coat (a gloss or matted coat will help even the edges between the colors, decals and help to prevent unwanted fingerprints from marring the finish).

Prior to cementing any parts together "test fit" them in order to be assure alignment. Also check for excess flash which may be present, use a sharp hobby knife or file if necessary.

If any parts are warped, apply a small amount of heat (such as a hair dryer or hot water) until you feel the resin soften. Gently bend back to shape.

We take pride in providing kits which are easy to assemble and give attention to detail and workmanship. Should you have any difficulty with missing/broken pieces or assembly please e-mail the address below:

SMTEMAIL@telusplanet.net

1

Tail Fin Assembly

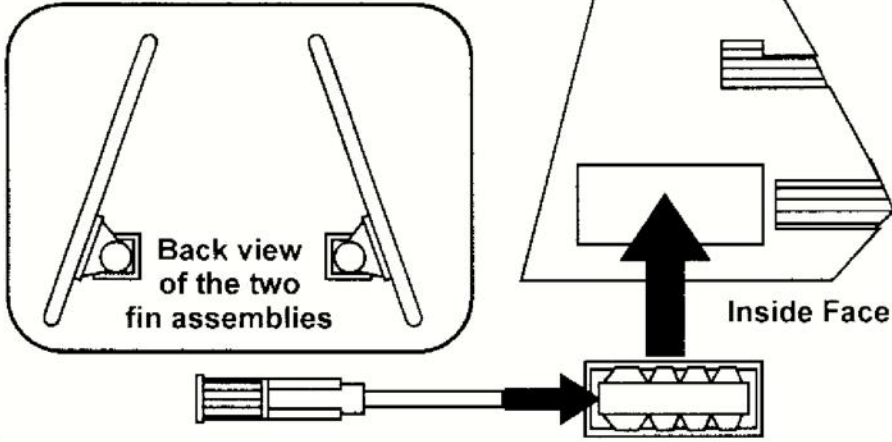

2

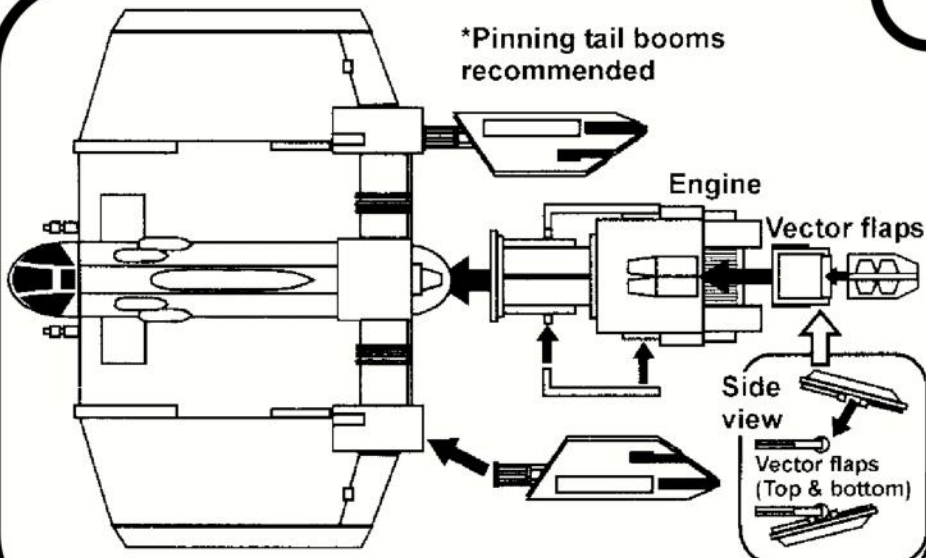

3

Underwing Ordnance

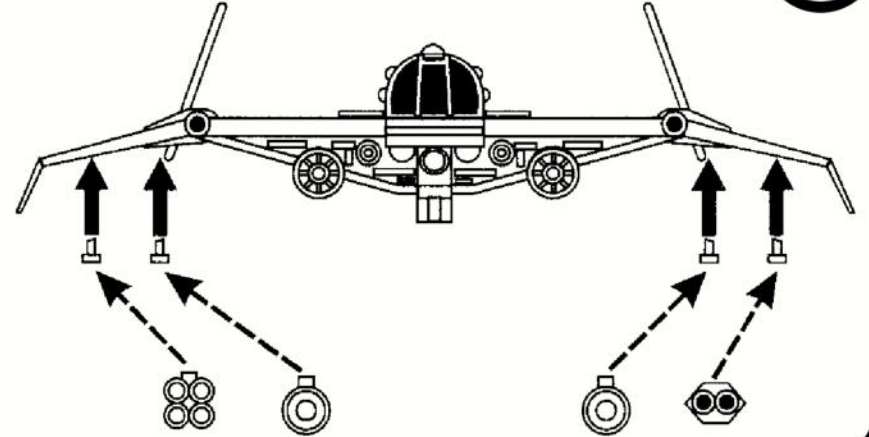

Painting

Paint to match the scheme that you have on your Cloakshape or finish differently to show that the parts were "liberated" from another spaceship. Your only limit is your imagination!